

**FRONT ELEVATION**  
SCALE: 1/8" = 1'-0"



**REAR ELEVATION**  
SCALE: 1/8" = 1'-0"

**Notice:**

SCHOENEMAN'S ASSUMES NO RESPONSIBILITY FOR STRUCTURAL OR DIMENSIONAL ERRORS OR OMISSIONS. THE CONTRACTOR AND/OR OWNER MUST VERIFY AND CHECK ALL NOTES, DETAILS, ELEVATIONS, SECTIONS, AND FLOOR PLANS. THE CONTRACTOR AND/OR OWNER IS RESPONSIBLE FOR MAKING SURE PLANS COMPLY TO BUILDING CODES AND REQUIREMENTS. NOTIFY SCHOENEMAN'S OF ANY ERRORS OR OMISSIONS FOR POSSIBLE CORRECTION.

**SCHOENEMAN'S**  
BUILDING MATERIALS CENTER  
ESTD. 1988

4000 S. Western Ave., Sioux Falls, SD 57105  
Phone: 605-339-0745 Fax: 605-331-2464  
600 N. Cliff Ave., Harrisburg, SD 57032  
Phone: 605-213-1100 Fax: 605-213-1107  
Also In:

Iowa: Spencer, Haverdorn

Contractor: **AFFORDABLE HOUSING SOLUTIONS**

Job: **1009 & 1011 N. BAHNSON AVE.**

Plan Number: **1514**

DRAWN BY: **Jim R.**

PAGE #: **1**

SCALE: **1/8" = 1'-0"**

DATE: **9/21/2020**

DATE: **9/21/2020**

PAGE #: **1**

DATE: **9/21/2020**

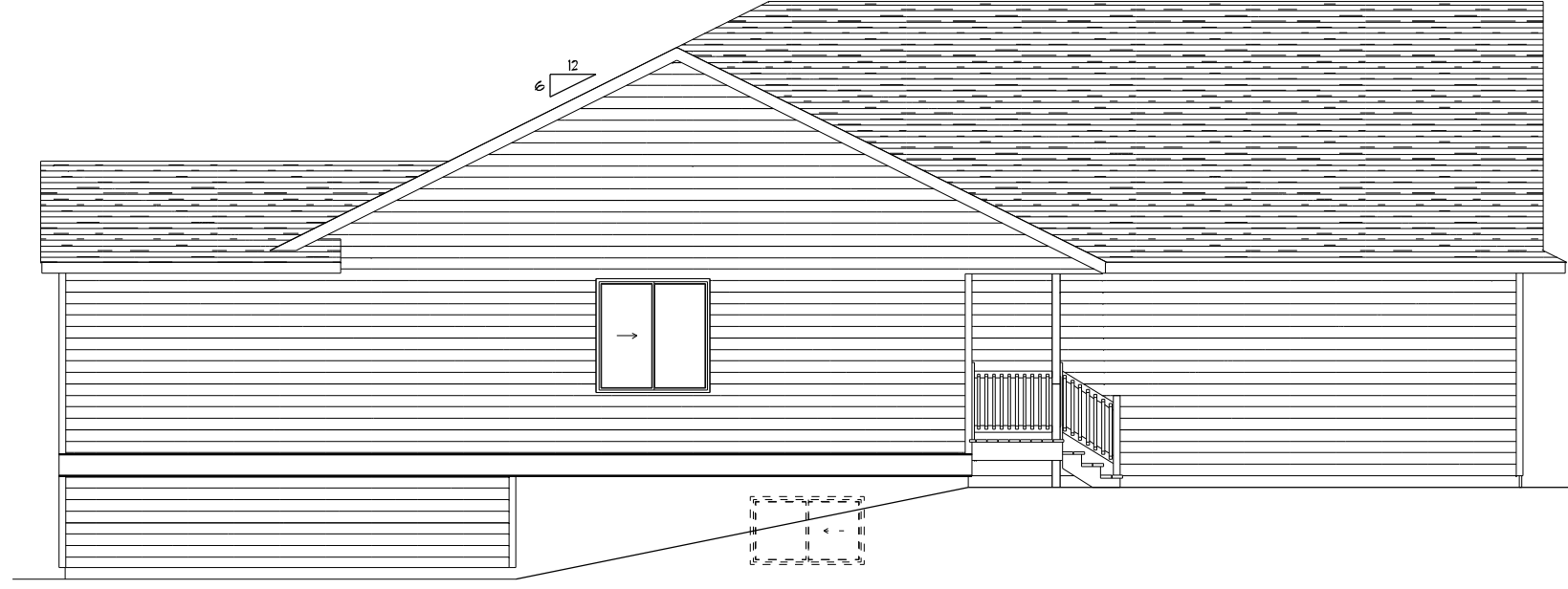

**LEFT ELEVATION**  
SCALE: 1/8" = 1'-0"

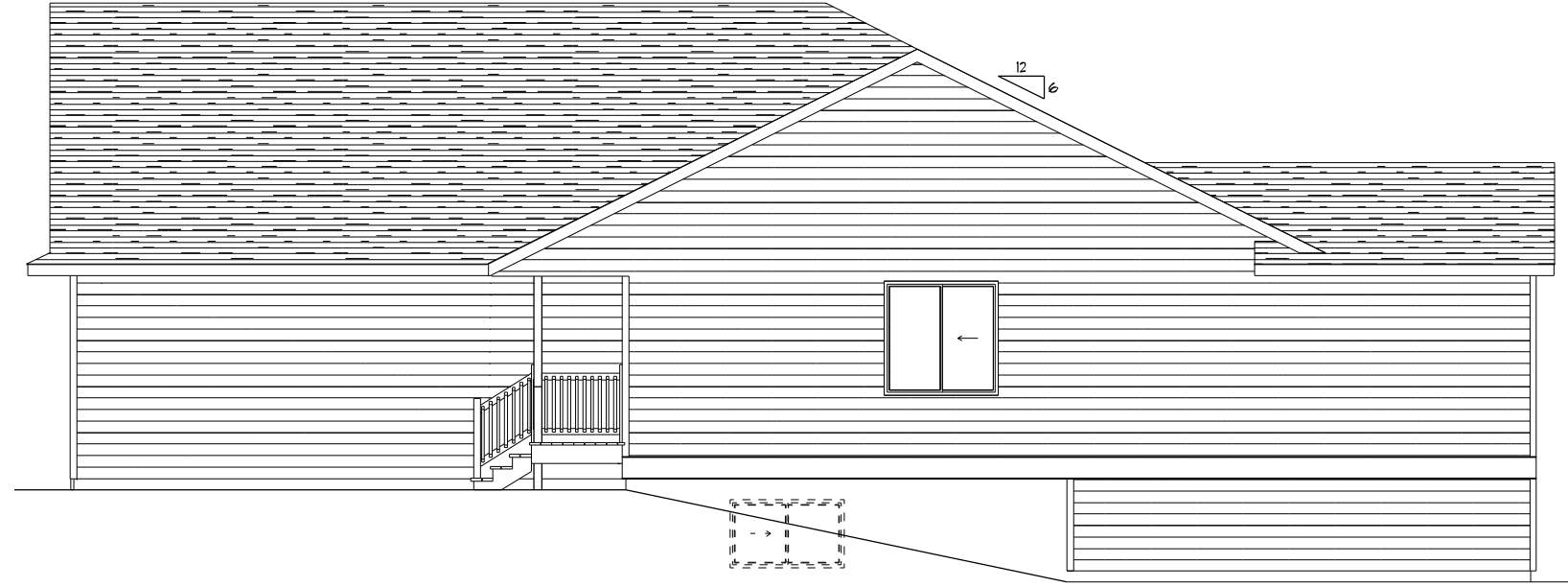

**RIGHT ELEVATION**  
SCALE: 1/8" = 1'-0"

**Notice:**

SCHOENEMAN'S ASSUMES NO RESPONSIBILITY FOR STRUCTURAL OR DIMENSIONAL ERRORS OR OMISSIONS. THE CONTRACTOR AND/OR OWNER MUST VERIFY AND CHECK ALL NOTES, DETAILS, ELEVATIONS, SECTIONS, AND FLOOR PLANS. THE CONTRACTOR AND/OR OWNER IS RESPONSIBLE FOR MAKING SURE PLANS COMPLY TO BUILDING CODES AND REQUIREMENTS. NOTIFY SCHOENEMAN'S OF ANY ERRORS OR OMISSIONS FOR POSSIBLE CORRECTION.

**SCHOENEMAN'S**  
BUILDING MATERIALS CENTER  
ESTD. *Empower - Connect* 1988

4000 S. Western Ave., Sioux Falls, SD 57105  
Phone: 605-339-0745 Fax: 605-331-2464  
600 N. Cliff Ave., Harrisburg, SD 57032  
Phone: 605-213-1100 Fax: 605-213-1107  
Also In:  
Iowa: Spencer, Haverden

Contractor:  
**AFFORDABLE HOUSING SOLUTIONS**

Job: **1009 & 1011 N. BAHNSON AVE.**

Plan Number:  
**1514**

DRAWN BY: **Jim R.**

PAGE #:

SCALE: **1/8" = 1'-0"**

**2 of 7**

DATE: **9/21/2020**

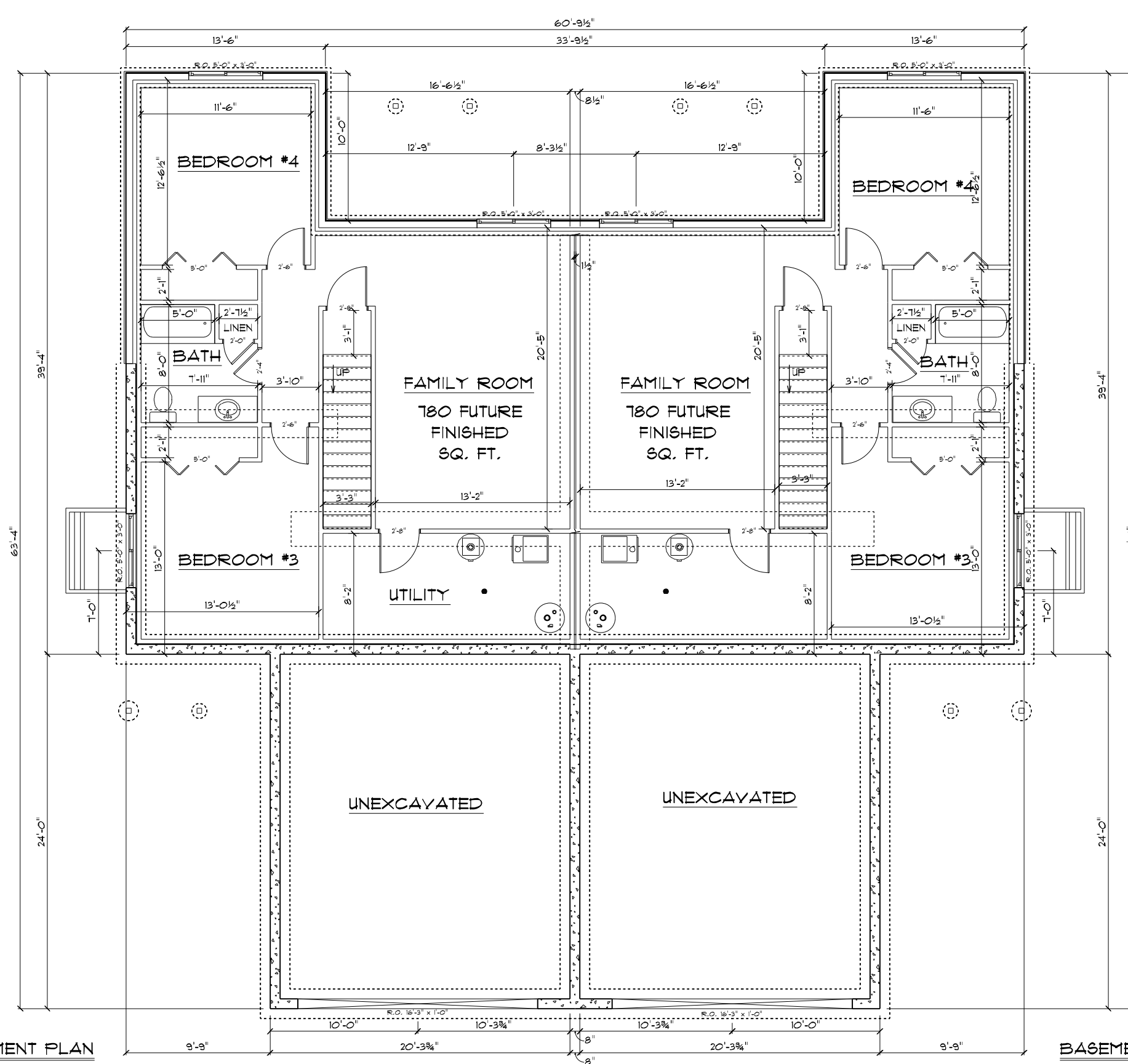

**BASEMENT PLAN**  
 SCALE: 1/8" = 1'-0"  
 NOTES:  
 180 FUTURE FINISHED SQ. FT.  
 8" CONCRETE WALLS  
 1'-9 1/2" CEILING HEIGHT  
 2X6 EXTERIOR GARDEN WALLS  
 2X4 INTERIOR WALLS

**BASEMENT PLAN**  
 SCALE: 1/8" = 1'-0"  
 NOTES:  
 180 FUTURE FINISHED SQ. FT.  
 8" CONCRETE WALLS  
 1'-9 1/2" CEILING HEIGHT  
 2X6 EXTERIOR GARDEN WALLS  
 2X4 INTERIOR WALLS

**Contractor:**  
**AFFORDABLE HOUSING SOLUTIONS**  
 Job: 1009 & 1011 N. BAHNSON AVE.  
 File Number: 1514  
 DRAWN BY: Jim R.  
 SCALE: 1/8" = 1'-0"  
 DATE: 9/21/2020

**Page #:**  
**3 of 7**

**SCHOENEMAN'S**  
 BUILDING MATERIALS CENTER  
 ESTD. 1988  
 4000 S. Western Ave., Sioux Falls, SD 57105  
 Phone: 605-339-0745 Fax: 605-331-2464  
 600 N. Cliff Ave., Harrisburg, SD 57032  
 Phone: 605-213-1100 Fax: 605-213-1107  
 Also In:  
 Iowa, Spencer, Hewarden

**Notice:**  
 SCHOENEMAN'S ASSUMES NO RESPONSIBILITY FOR STRUCTURAL OR DIMENSIONAL ERRORS OR OMISSIONS. THE CONTRACTOR AND/OR OWNER MUST VERIFY AND CHECK ALL NOTES, DETAILS, ELEVATIONS, SECTIONS, AND FLOOR PLANS. THE CONTRACTOR AND/OR OWNER IS RESPONSIBLE FOR MAKING SURE PLANS COMPLY TO BUILDING CODES AND REQUIREMENTS. NOTIFY SCHOENEMAN'S OF ANY ERRORS OR OMISSIONS FOR POSSIBLE CORRECTION.

**MAIN FLOOR PLAN**

SCALE: 1/8" = 1'-0"  
 NOTES:  
 1030 SQ. FT.  
 8'-1 1/8" CEILING HEIGHT  
 2X6 EXTERIOR WALLS  
 2X4 INTERIOR WALLS  
 9'-9 3/8" GARAGE WALL HEIGHT  
 2X4 GARAGE WALLS

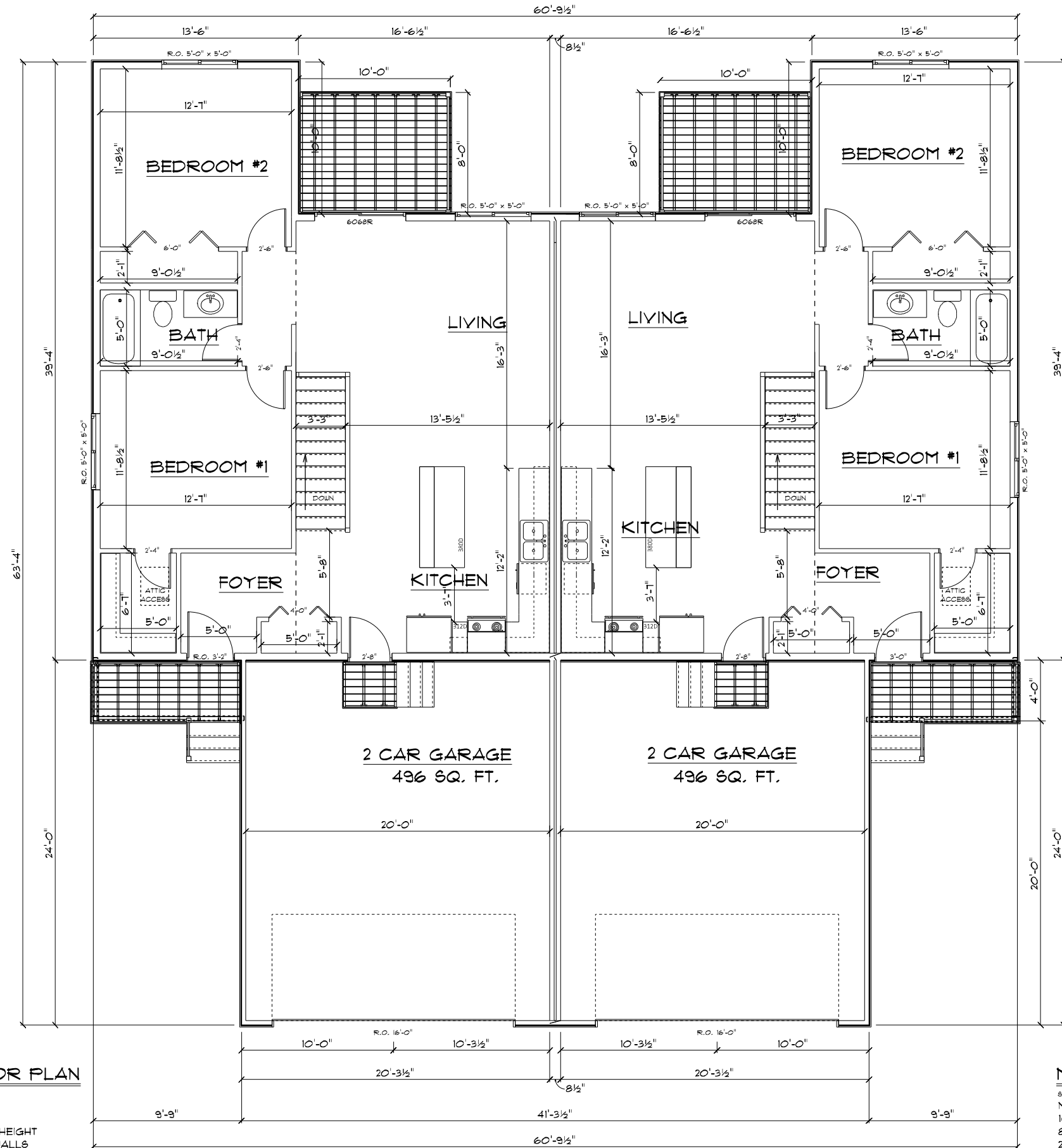

**MAIN FLOOR PLAN**

SCALE: 1/8" = 1'-0"  
 NOTES:  
 1030 SQ. FT.  
 8'-1 1/8" CEILING HEIGHT  
 2X6 EXTERIOR WALLS  
 2X4 INTERIOR WALLS  
 9'-9 3/8" GARAGE WALL HEIGHT  
 2X4 GARAGE WALLS

**Notice:**

SCHOENEMAN'S ASSUMES NO RESPONSIBILITY FOR STRUCTURAL OR DIMENSIONAL ERRORS OR OMISSIONS. THE CONTRACTOR AND/OR OWNER MUST VERIFY AND CHECK ALL NOTES, DETAILS, ELEVATIONS, SECTIONS, AND FLOOR PLANS. THE CONTRACTOR AND/OR OWNER IS RESPONSIBLE FOR MAKING SURE PLANS COMPLY TO BUILDING CODES AND REQUIREMENTS. NOTIFY SCHOENEMAN'S OF ANY ERRORS OR OMISSIONS FOR POSSIBLE CORRECTION.

**SCHOENEMAN'S**  
 BUILDING MATERIALS CENTER  
 ESTD. 1988

4000 S. Western Ave., Sioux Falls, SD 57105  
 Phone: 605-339-0745 Fax: 605-331-2464  
 600 N. Cliff Ave., Harrisburg, SD 57032  
 Phone: 605-213-1100 Fax: 605-213-1107  
 Also In:  
 Iowa: Spencer, Hawarden

Contractor: **AFFORDABLE HOUSING SOLUTIONS**

Job: **1009 & 1011 N. BAHNSON AVE.**

File Number: **1514**

DRAWN BY: **Jim R.**

PAGE #: **4 of 7**

SCALE: **1/8" = 1'-0"**

DATE: **9/21/2020**

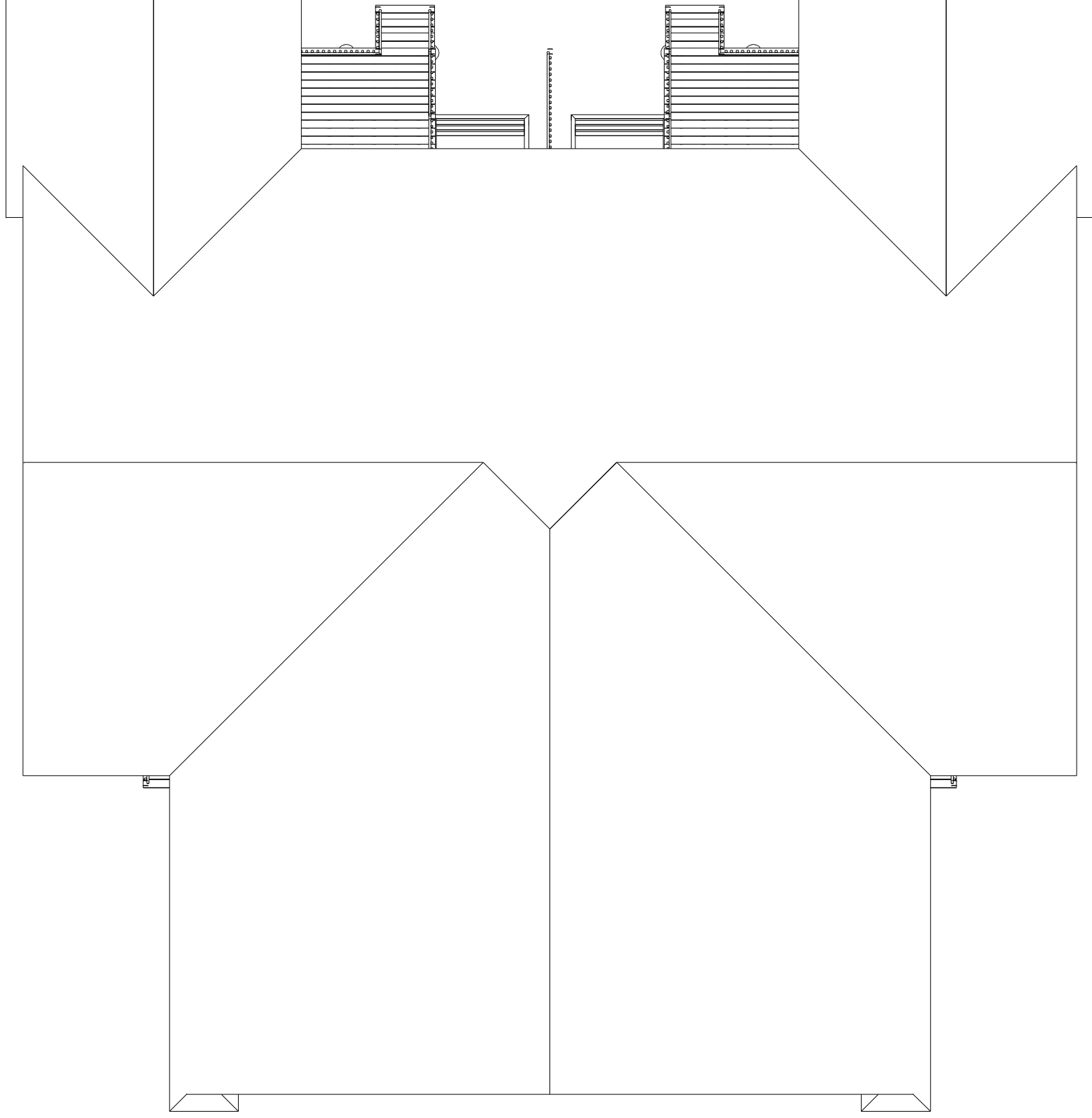

**Notice:**

SCHOENEMAN'S ASSUMES NO RESPONSIBILITY FOR STRUCTURAL OR DIMENSIONAL ERRORS OR OMISSIONS. THE CONTRACTOR AND/OR OWNER MUST VERIFY AND CHECK ALL NOTES, DETAILS, ELEVATIONS, SECTIONS, AND FLOOR PLANS. THE CONTRACTOR AND/OR OWNER IS RESPONSIBLE FOR MAKING SURE PLANS COMPLY TO BUILDING CODES AND REQUIREMENTS. NOTIFY SCHOENEMAN'S OF ANY ERRORS OR OMISSIONS FOR POSSIBLE CORRECTION.

**SCHOENEMAN'S**  
 BUILDING MATERIALS CENTER  
 ESTD. *Empower - Connect* 1988

4000 S. Western Ave., Sioux Falls, 57105  
 Phone: 605-339-0745 Fax: 605-331-2464  
 600 N. Cliff Ave., Harrisburg 57032  
 Phone: 605-213-1100 Fax: 605-213-1107  
 Also In:  
 Iowa, Spencer, Haverden

Contractor: **AFFORDABLE HOUSING SOLUTIONS**

Job: **1009 & 1011 N. BAHNSON AVE.**

Plan Number: **1514**

DRAWN BY: **Jim R.**

PAGE #: **5**

SCALE: **1/8" = 1'-0"**

DATE: **9/21/2020**

5 of 7

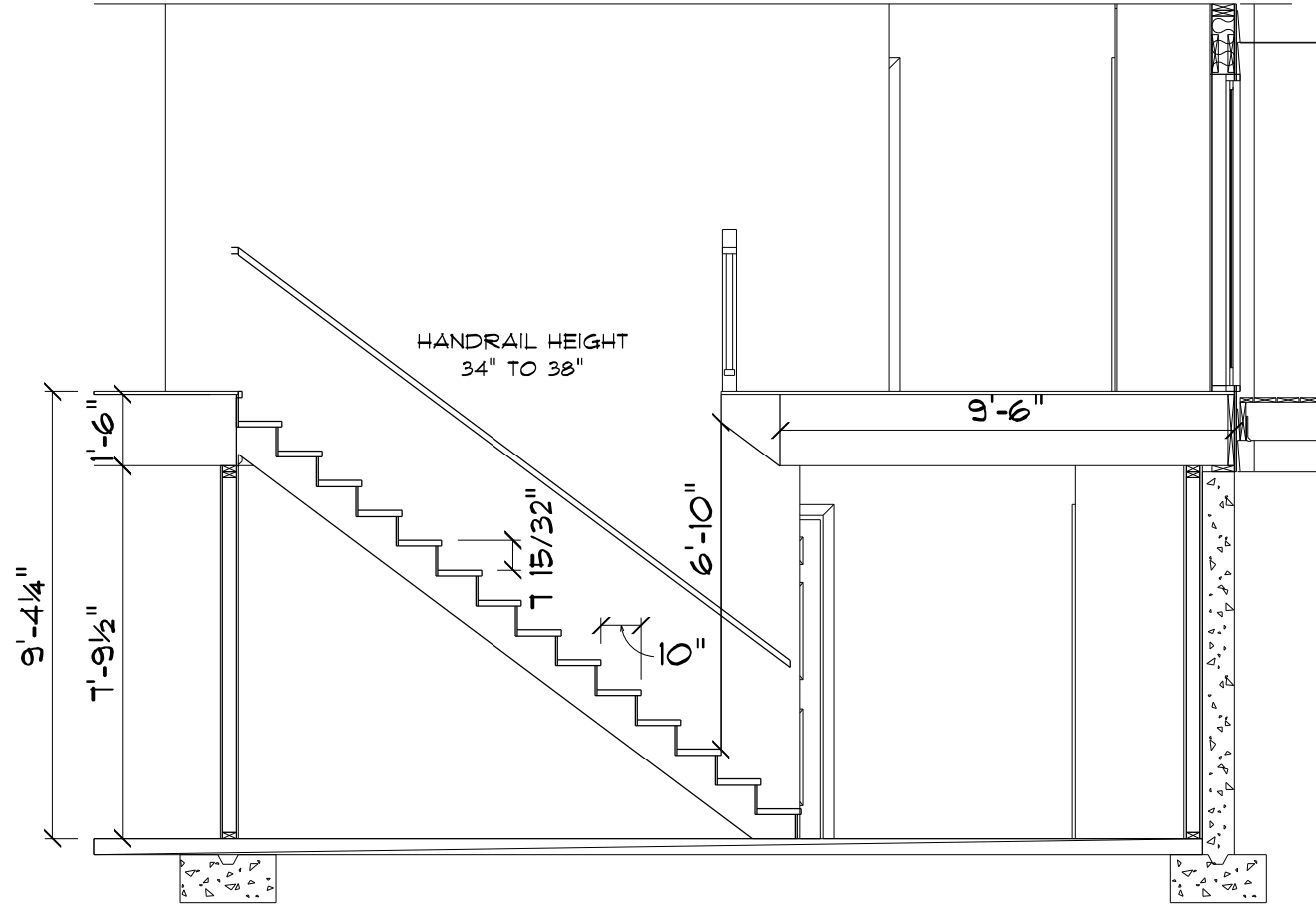

STAIR SECTION

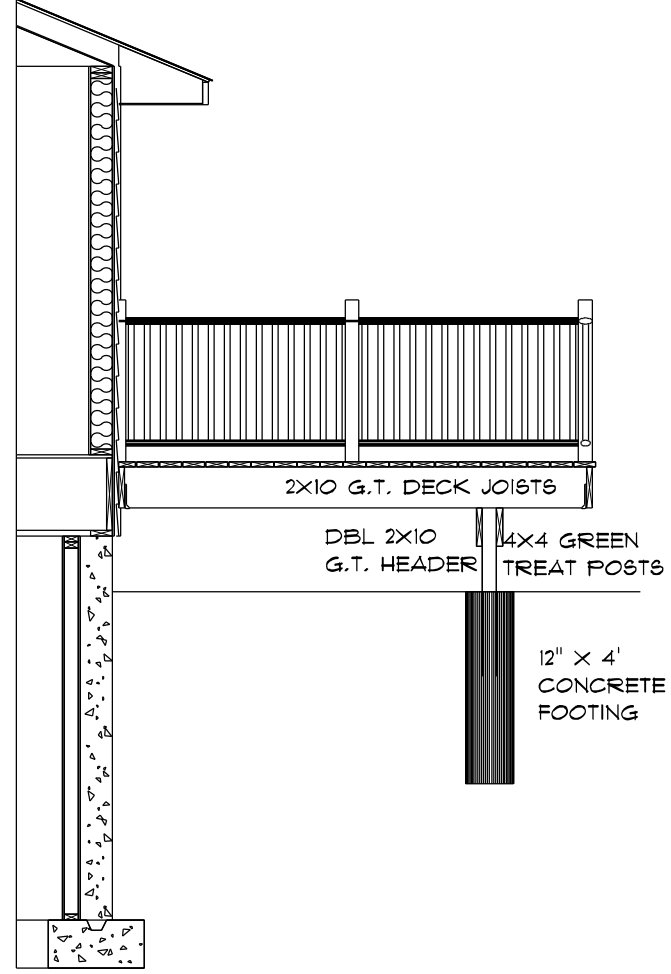

**Notice:**

SCHOENEMAN'S ASSUMES NO RESPONSIBILITY FOR STRUCTURAL OR DIMENSIONAL ERRORS OR OMISSIONS. THE CONTRACTOR AND/OR OWNER MUST VERIFY AND CHECK ALL NOTES, DETAILS, ELEVATIONS, SECTIONS, AND FLOOR PLANS. THE CONTRACTOR AND/OR OWNER IS RESPONSIBLE FOR MAKING SURE PLANS COMPLY TO BUILDING CODES AND REQUIREMENTS. NOTIFY SCHOENEMAN'S OF ANY ERRORS OR OMISSIONS FOR POSSIBLE CORRECTION.

**SCHOENEMAN'S**  
 BUILDING MATERIALS CENTER  
 ESTD. *Empower - Connect* 1988

4000 S. Western Ave., Sioux Falls, SD 57105  
 Phone: 605-339-0745 Fax: 605-331-2464  
 600 N. Cliff Ave., Harrisburg, SD 57032  
 Phone: 605-213-1100 Fax: 605-213-1107  
 Also In:

Iowa: Spencer, Haurdard

Contractor:  
**AFFORDABLE HOUSING SOLUTIONS**

Job: 1009 & 1011 N.  
**BAHNSON AVE.**

Plan Number:  
 1514

DRAWN BY: Jim R.

PAGE #:

SCALE: 1/8" = 1'-0"

6 of 7

DATE: 9/21/2020

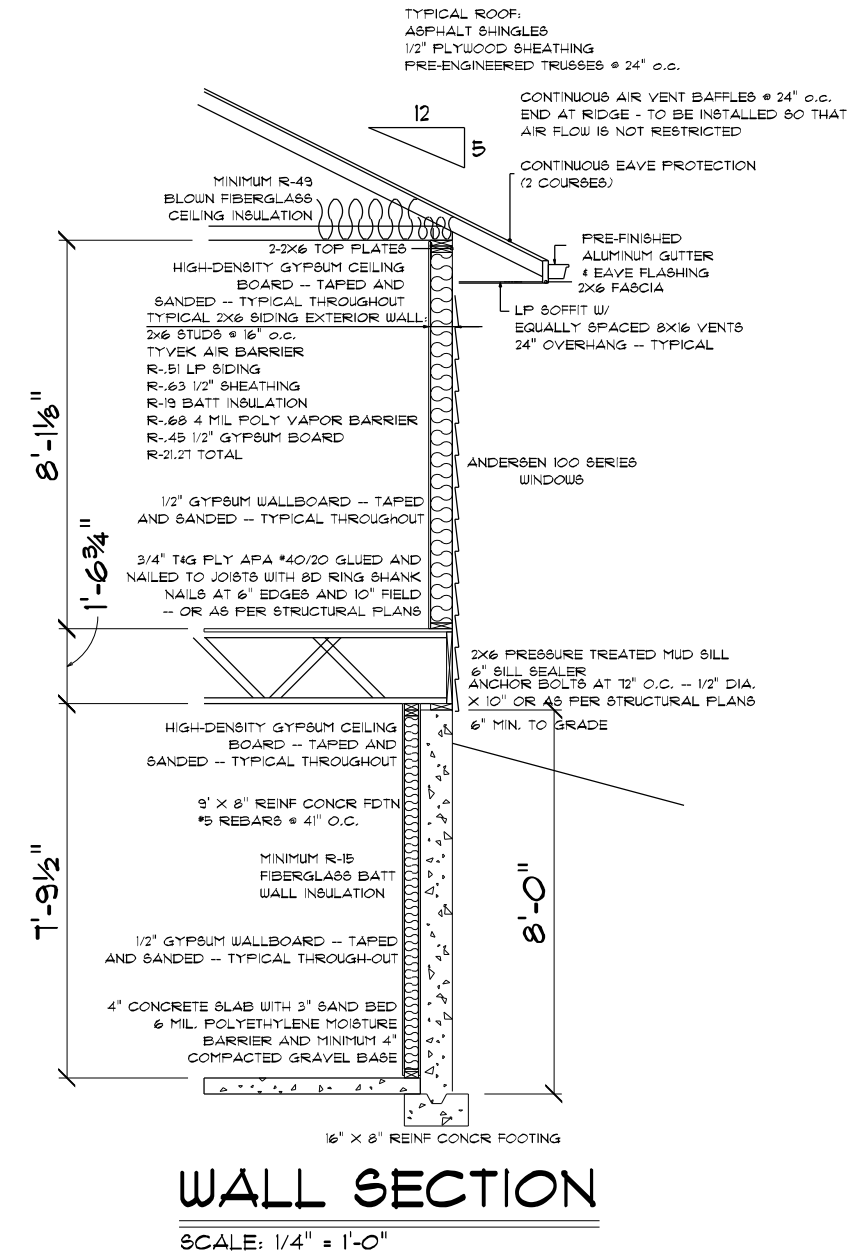
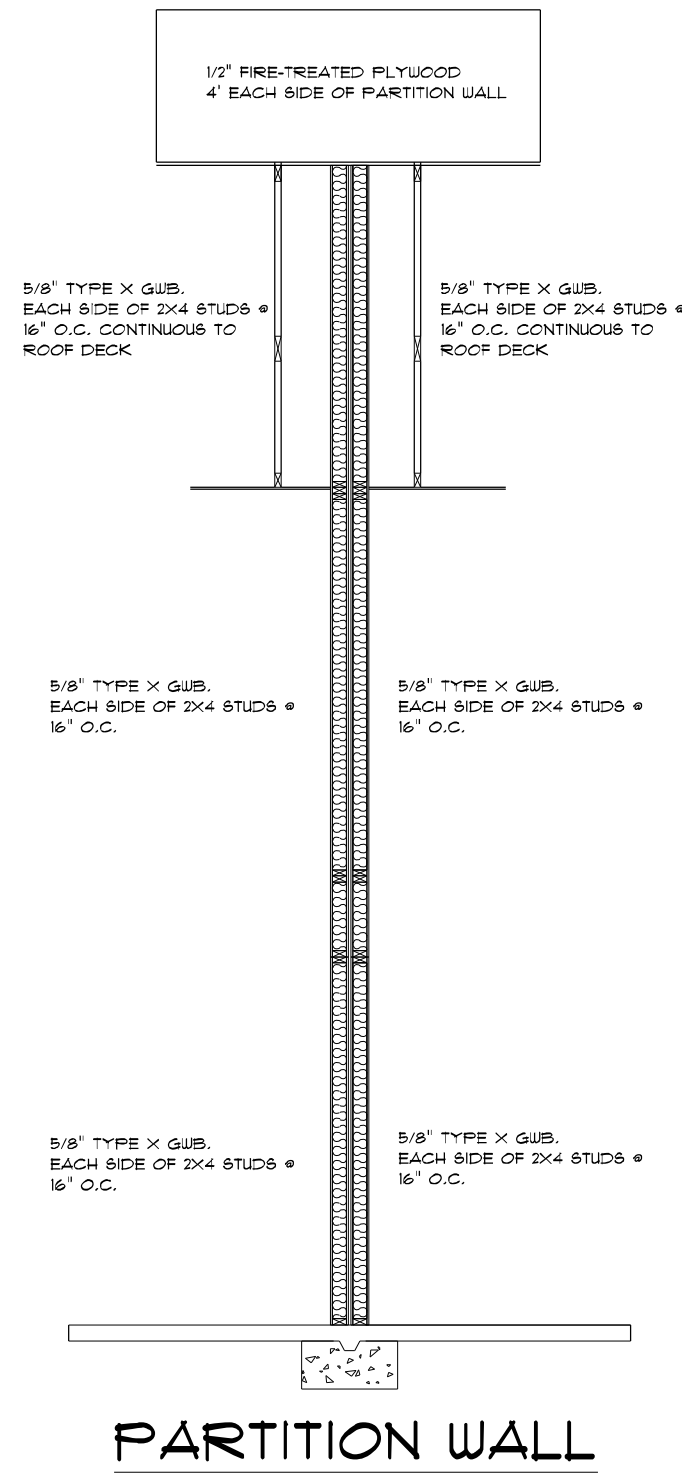
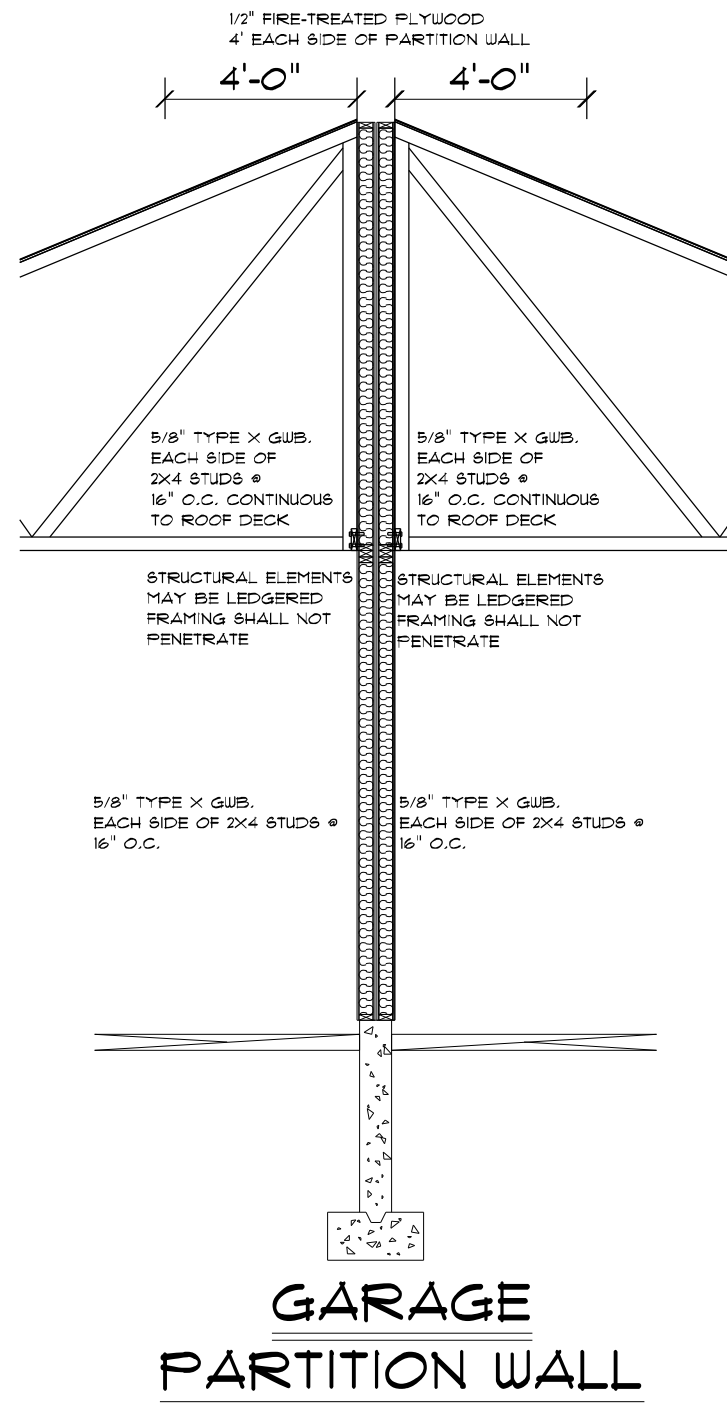

Contractor: **SCHOENEMAN'S AFFORDABLE HOUSING SOLUTIONS**

Job: **1009 & 1011 N. BAHNSON AVE.**

File Number: **1514**

DRAWN BY: **Jim R.**

SCALE: **1/8" = 1'-0"**

DATE: **9/21/2020**

Page #: **7 of 7**

**SCHOENEMAN'S BUILDING MATERIALS CENTER**  
ESTD. 1989

4000 S. Western Ave., Sioux Falls, SD 57105  
Phone: 605-339-0745 Fax: 605-331-2464  
600 N. Cliff Ave., Harrisburg, SD 57032  
Phone: 605-213-1100 Fax: 605-213-1107

Also In: Iowa, Spencer, Hewarden

**Notice:**

SCHOENEMAN'S ASSUMES NO RESPONSIBILITY FOR STRUCTURAL OR DIMENSIONAL ERRORS OR OMISSIONS. THE CONTRACTOR AND/OR OWNER MUST VERIFY AND CHECK ALL NOTES, DETAILS, ELEVATIONS, SECTIONS, AND FLOOR PLANS. THE CONTRACTOR AND/OR OWNER IS RESPONSIBLE FOR MAKING SURE PLANS COMPLY TO BUILDING CODES AND REQUIREMENTS. NOTIFY SCHOENEMAN'S OF ANY ERRORS OR OMISSIONS FOR POSSIBLE CORRECTION.



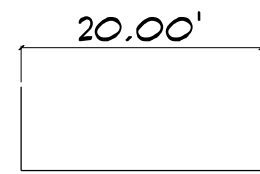
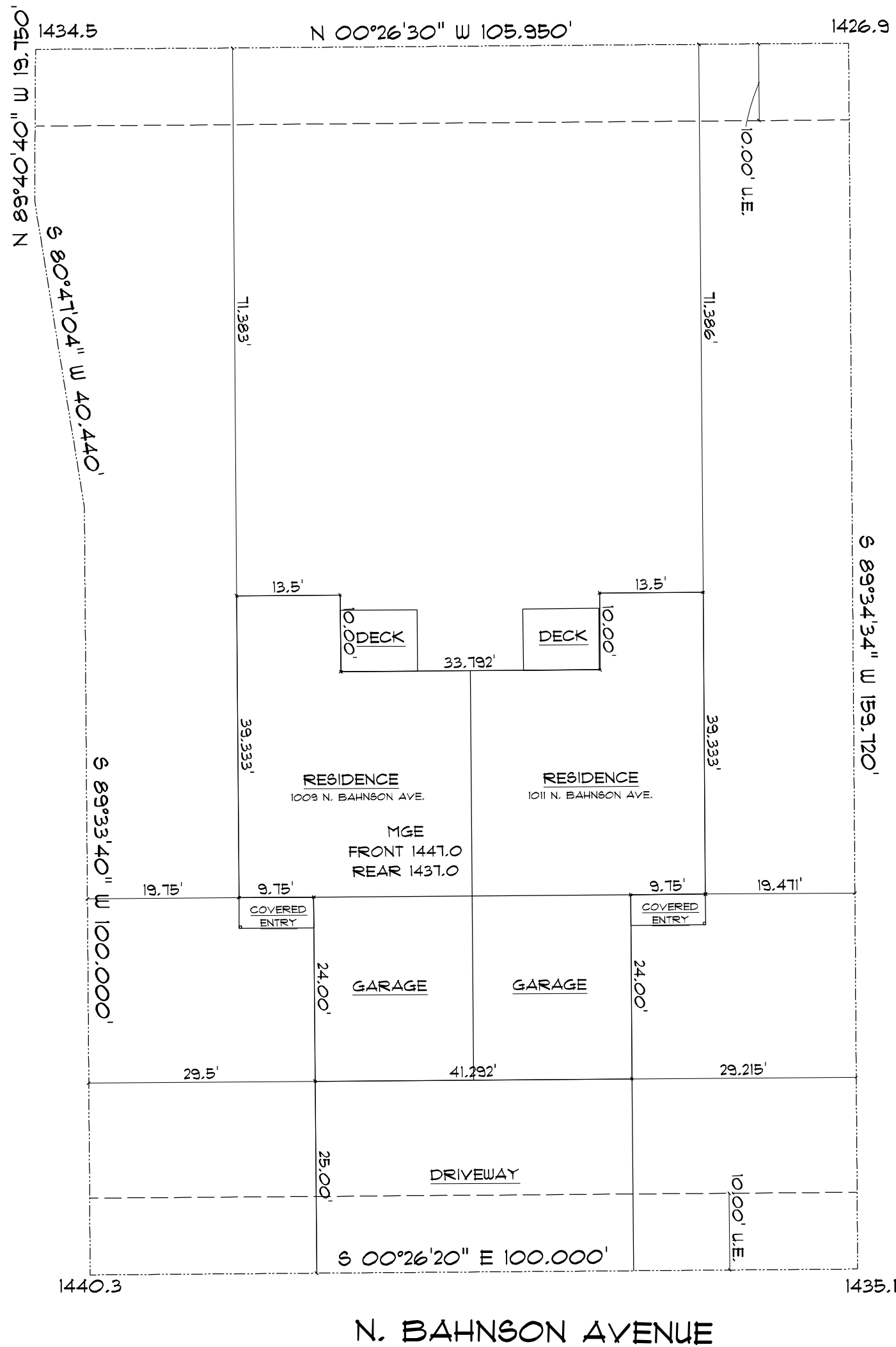

**LEGAL**

TIMBERLINE ESTATES ADDITION IN THE CITY OF  
 SIOUX FALLS, SD MINNEHAHA COUNTY  
 1009 & 1011 N. BAHNSON AVE.  
 LOT 4B  
 BLOCK 7  
 16217.7 SQ. FT.

**Notice:**

SCHOENEMAN'S ASSUMES NO RESPONSIBILITY FOR STRUCTURAL OR DIMENSIONAL ERRORS OR OMISSIONS. THE CONTRACTOR AND/OR OWNER MUST VERIFY AND CHECK ALL NOTES, DETAILS, ELEVATIONS, SECTIONS, AND FLOOR PLANS. THE CONTRACTOR AND/OR OWNER IS RESPONSIBLE FOR MAKING SURE PLANS COMPLY TO BUILDING CODES AND REQUIREMENTS. NOTIFY SCHOENEMAN'S OF ANY ERRORS OR OMISSIONS FOR POSSIBLE CORRECTION.

**SCHOENEMAN'S**  
 BUILDING MATERIALS CENTER  
 ESTD. Employee-Owned 1988

4000 S. Western Ave., Sioux Falls 57109  
 Phone: 605-339-0745 Fax: 605-331-2464  
 600 N. Cliff Ave., Harrisburg 57032  
 Phone: 605-213-1100 Fax: 605-213-1107  
 Also In:  
 Iowa: Spencer, Haurden

Contractor: **AFFORDABLE HOUSING SOLUTIONS**

Job: **1009 & 1011 N. BAHNSON AVE.**

Plan Number: **1514**

DRAWN BY: **Jim R.**

PAGE #: **SITE**

SCALE: **1" = 15'-0"**

DATE: **9/21/2020**